

DESIGN FEATURES:

- 1/4"-2" : 2000 WOG : 2-1/2 - 3" : 1500 WOG
- Blow-out Proof Stem
- Seal Weld Construction
- Pressure Balance Hole in Ball Slot
- Full Port
- NACE MR-0175
- Various Thread Standards Available
- Casting Approved by TÜV AD 2000-Merkblatt W0



APPLICABLE STANDARDS:

- Design Standard: MSS SP-110;
- Pipe Thread: ASME B 1.20.1,
DIN 2999/259, ISO 228/1;
- Inspection & Testing: MSS SP-110

TECHNICAL INFORMATION

SIZE	CV	Weight Kg	Weight Lb
1/4"	6	0.32	0.71
3/8"	6	0.33	0.73
1/2"	24	0.34	0.75
3/4"	32	0.49	1.08
1"	38	0.88	1.94
1-1/4"	70	1.30	2.87
1-1/2"	95	1.90	4.19
2"	210	2.60	5.73
2-1/2"	400	5.80	12.79
3"	550	8.80	19.40

■ PRESSURE - TEMPERATURE CHART

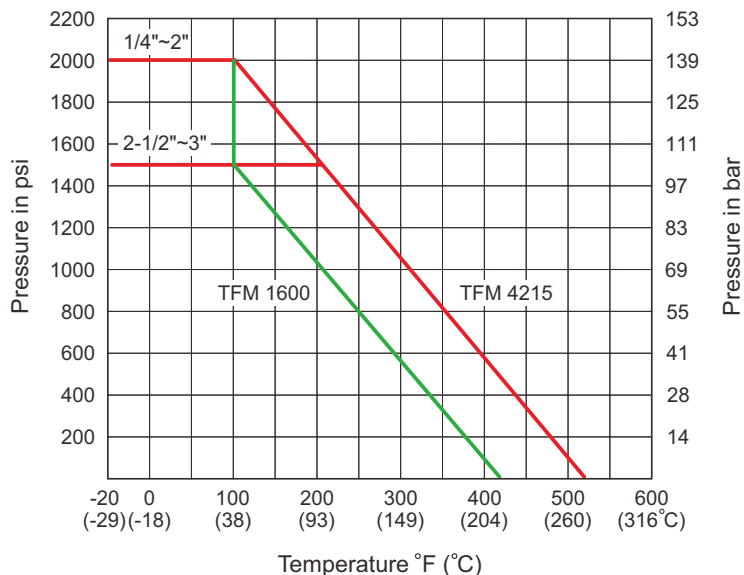

MATERIAL OF CONSTRUCTION

NO.	PART NAME	MATERIALS
1	Body	CF8M
2	End Cap	CF8M
3	Ball	CF8M
4	Body Seat	TFM 1600 / TFM 4215
5	Stem	SS316
6	Thrust Washer	PTFE
7	Packing	PTFE / GRAFOIL
8	Gland Nut	SS304
9	Stem Washer	SS304
10	Stem Nut	A194-8
11	Handle	SS304
12	Handle Sleeve	VINYL PLASTIC
13	Locking Device	SS304

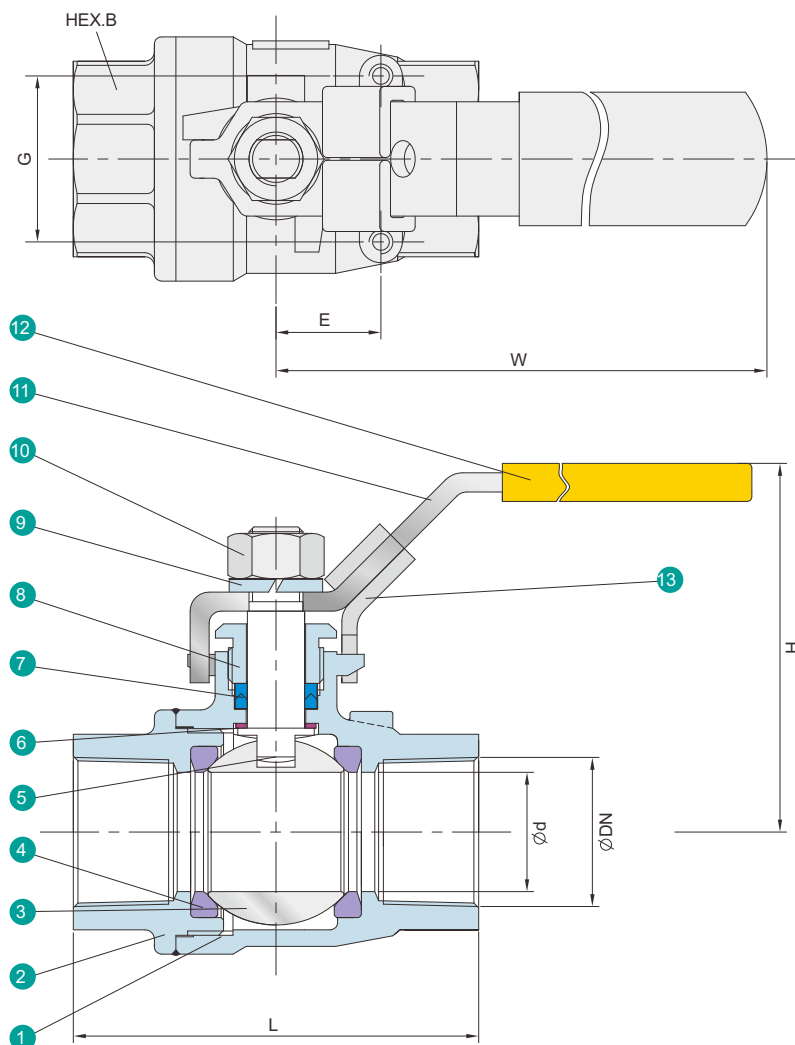

DIMENSION TABLE

Unit: mm

SIZE	Ød	L	H	W	E	G	HEX.B	ØDN
1/4"	10.6	58.0	58.0	100.0	12.7	28.5	23.5	
3/8"	12.0	58.0	58.0	100.0	12.7	28.5	23.5	NPT
1/2"	15.0	62.0	58.0	100.0	12.7	28.5	25.0	BSP
3/4"	19.0	72.4	64.0	129.0	22.0	34.8	32.0	PT
1"	22.5	85.0	77.0	156.0	22.0	34.8	41.0	
1-1/4"	30.0	94.0	83.0	156.0	23.6	38.1	50.0	
1-1/2"	36.0	105.0	96.0	182.5	23.6	38.1	56.0	DIN
2"	47.0	125.0	102.0	182.5	23.6	38.1	70.0	
2-1/2"	61.0	155.0	129.0	252.0	35.0	65.0	83.0	etc.
3"	73.0	173.0	138.5	252.0	35.0	65.0	102.0	

Unit: inch

SIZE	Ød	L	H	W	E	G	HEX.B	ØDN
1/4"	0.42	2.28	2.28	3.94	0.50	1.12	0.93	
3/8"	0.47	2.28	2.28	3.94	0.50	1.12	0.93	NPT
1/2"	0.59	2.44	2.28	3.94	0.50	1.12	0.98	BSP
3/4"	0.75	2.85	2.52	5.08	0.87	1.37	1.26	
1"	0.89	3.35	3.03	6.14	0.87	1.37	1.61	PT
1-1/4"	1.18	3.70	3.27	6.14	0.93	1.50	1.97	
1-1/2"	1.42	4.13	3.78	7.19	0.93	1.50	2.20	DIN
2"	1.85	4.92	4.02	7.19	0.93	1.50	2.76	
2-1/2"	2.40	6.10	5.08	9.92	1.38	2.56	3.27	etc.
3"	2.87	6.81	5.45	9.92	1.38	2.56	4.02	